

Chemical Fume Hoods

Environmental Health and Safety

974-5084



Regulatory References

- Prudent Practices in the Laboratory – 2011 (National Research Council of The National Academies):
 - “Laboratory chemical hoods are the most important components used to protect laboratory personnel from exposure to hazardous chemicals and agents.”
- OSHA’s Laboratory Standard on having a properly working hood:
 - **1910.1450(e)(3)(iii)** A requirement that fume hoods and other protective equipment are functioning properly and specific measures that shall be taken to ensure proper and adequate performance of such equipment;
- [OSHA Lab Standard](#)
- UT Chemical Fume Hood Policy

<http://web.utk.edu/~ehss/safety%20manual/smpdf/Chemical%20Fume%20Hoods%201%200%20form.pdf>

Chemical Fume Hoods

- A Chemical Fume Hood is a chemical and fire resistant enclosure with one large opening at the face, with a moveable window called the sash. It offers protection from fumes and vapors for the user.
- This training will provide users with information regarding proper usage, safety, and personal protective equipment.

Chemical Hood Parts

- Exhaust Duct – exhausts fumes and vapors.
- Baffles – maintain a uniform airflow across the face of the hood
- Airfoil – prevent turbulent eddies at the face.
- Sash – see through barrier.
- Bypass Grill – helps maintain constant face velocity when the hood is closed.

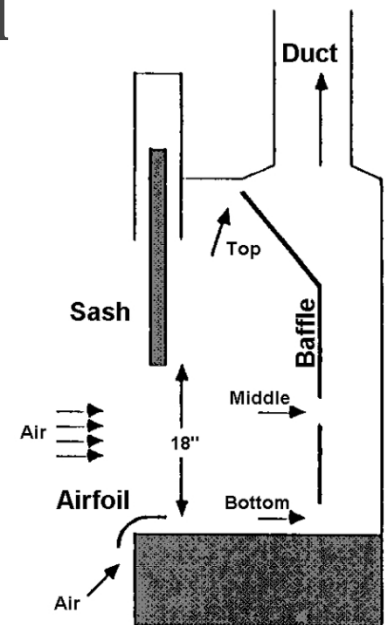
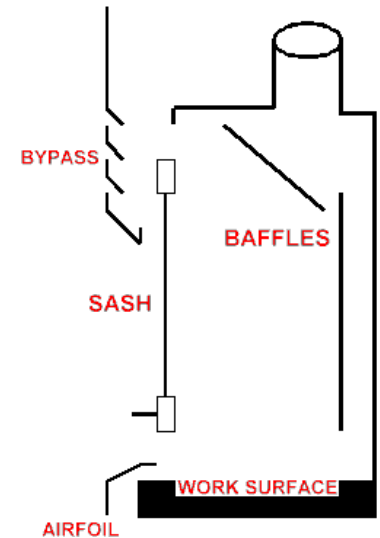

Chemical Fume Hood Types

- Vertical Sash
 - A hood with a single vertical rising sash.
- Horizontal Sash
 - Hood with two or more horizontal sliding sashes.
- Combination Sash
 - Hood with a vertical rising sash as well as two or more moveable horizontal sashes.
- Constant Air Volume (CAV)
 - Exhausts the same amount of air at all times, regardless of sash height.
- Variable Air Volume (VAV)
 - Also called a Constant Velocity Hood
 - Varies the amount of air exhausted, based on sash height, to maintain a constant face velocity.
 - Significantly more energy efficient verses CAV hoods.

Chemical Fume Hood Types



← Vertical Sash



Horizontal or Combination Sash →

Hood Operation

- Check the EHS inspection sticker on the hood (usually on the sash) to ensure it has been inspected within the past 12 months.
- EHS measures the face velocity, the average velocity of air drawn through the face of the hood, of all hoods annually. Any deficiencies are noted and referred to UT Facilities Services for correction if the hood is operating outside of the 90 to 120 feet per minute (fpm) range.
- Check the sash height:
 - The sash height should not be set above 18”.
 - Keep the sash closed unless you are setting up or actively using the hood.



Hood Operation

- The recommended best practice for a combination sash hood (horizontal sliding panels within a vertical sliding sash) relies on completely closing the vertical sash while working through the horizontal sliders. Regular use of the horizontal sliding panels with the vertical sliding sash closed reduces chemical exposure and reduces energy expense.
- The vertical sliding sash should only be open during set up, not while manipulating objects in the hood with reactions present.
- Always close the sash when finished with the hood or when leaving experiments unattended. This can help contain fires and explosions within a hood.



Working at Fume Hoods

- Work at least 6 inches inside the hood to keep vapors from exiting. All equipment should be at least 9 inches away from the hood face.

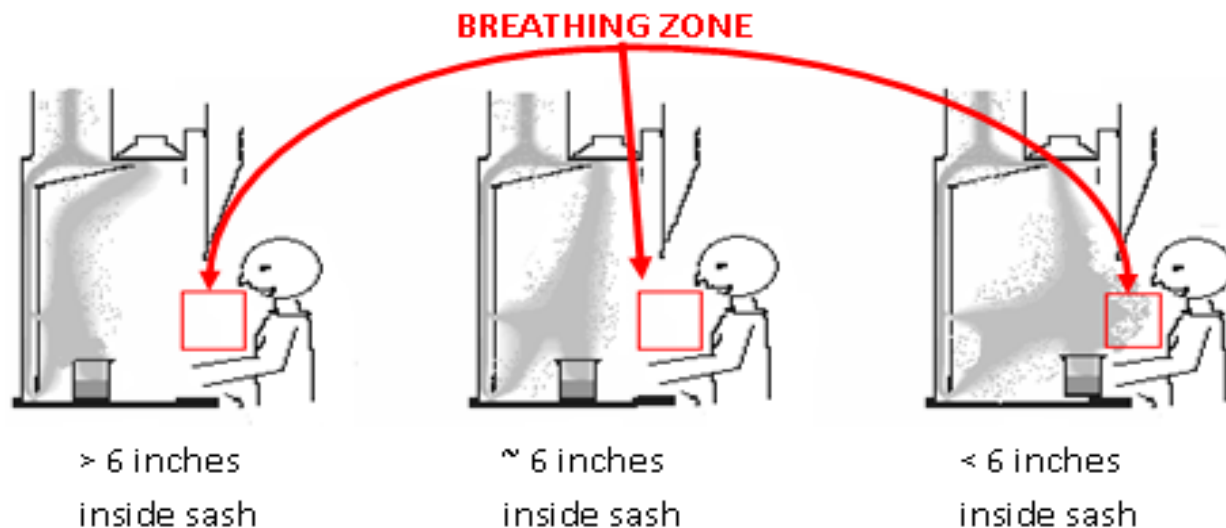

- Never allow your head to enter the hood.

Hood Operation



- Avoid creating air currents across the face of the hood.
 - Reduce pedestrian traffic in front of hoods.
 - Do not position fans or air conditioners in ways that would direct airflow across the face of the hood.
 - Keep lab doors and windows closed unless lab ventilation design requires they be open.

Hood Operation

- Take steps to maximize chemical vapor containment.
 - Place blocks under large equipment to allow air to flow underneath.
 - Keep the work area and bottom baffles clear from clutter.
 - Do not use your hood for long term chemical storage. Items in a hood will impede and disturb the exhaust airflow and potentially reduce or eliminate the safety factor. This includes Hazardous Waste storage.
 - Remove unnecessary equipment and materials that may block the exhaust slots at the rear of the hood.

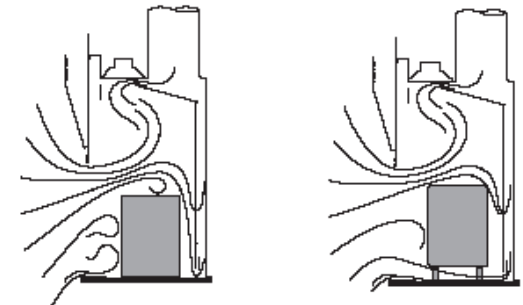

Provide 2" lift for large equipment

Hood Operation

- Do not block or clutter your hood with chemicals or equipment.



Hood Safety

- Remove electrical units or other spark sources from the hood when flammable liquids or gases are present.
- Do not place power strips or surge protectors in the hood. Plug in all electrical equipment outside of the hood.
- Eye protection is required for all faculty, staff, students, and visitors in laboratories, even when using fume hoods.
- Know the hazards of the chemical(s) you are working with.
- Do not use hazardous chemicals in laminar flow cabinets (HEPA filtered cabinets designed to prevent contamination of the samples or items within the hood).



Hood Safety

- Fume hoods are integral pieces of safety equipment. If not utilized properly, injury, or worse, can occur.
- Proper containment of substances may not occur due to inadequate flow rates, a sash being left open or opened too high, or due to excess clutter.
- Slipping belts or exhaust ducts blocked due to paper towels, aluminum foil, or chem wipes can also reduce airflow.



Hood Modifications

- Maintain airflow and containment
 - Do not block the airfoil.
 - Do not add shelving to the hood.
 - Do not remove the side panels.
 - Do not modify the hood in any way.

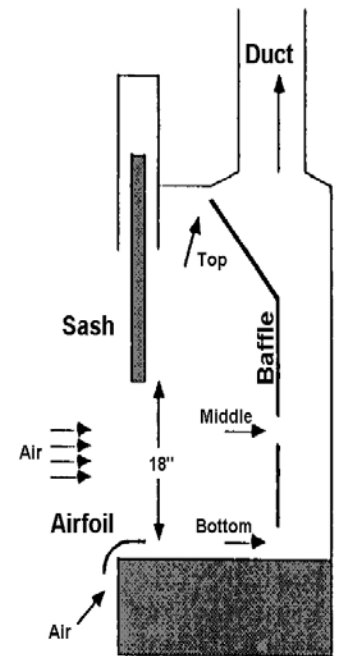

Alarms

- Always test the airflow alarm prior to using the hood.
- Never work in a malfunctioning hood.
- The alarm on the laboratory chemical hood is designed to notify you if the hood is not performing as desired which could lead to overexposure to chemicals. If the alarm is triggered, take the following steps:
 - Shut down your experiment
 - Close the sash
 - Contact Facilities Services a 946-7777

Power Outages and Repairs

- If the alarm sounds due to a scheduled power outage, post the hood as “Out of Service” until power is restored.
 - Turn the alarm back on before any work is conducted in the hood.
- If the hood gauge indicates poor hood performance or your hood needs repair, contact Facilities Services at 946-7777.
- A correctly operating hood sash can be raised and lowered smoothly without a lot of effort. If you have difficulty operating the sash, or it can not be lowered completely, contact Facilities Services. Make sure that equipment, cords, tubing, etc. is not configured in such a way that the sash cannot be lowered quickly and completely.

Radioactive Materials Usage in Hoods



- The Radiation Safety department tests the air velocity of all hoods in which radioactive materials are used. For more information, please contact Radiation Safety at 974-5580.

Virology/Bacteriology

- Chemical Hoods should not be used for virology or bacteriology work.
- When working with cultures, use a biological safety cabinet.
- For questions, please contact Office of Biosafety at 974-1938.



Perchloric Acid

- Perchloric Acid should be used in Perchloric Acid Fume Hoods Only.
 - Perchloric Acid fume hoods are built with stainless steel surfaces, duct work, and fans to minimize the corrosive and reactive effects of the acid.
 - They also have wash-down systems made up of water fog nozzles dispersed throughout the system. When used, these can remove the buildup of hazardous, reactive perchlorates.
 - Wash-down systems should be tested periodically.
 - Do not use a Perchloric Acid Hood if the wash-down system is not working properly.

Snorkel Ducts



- Some laboratories are equipped with snorkel ducts, which consist of a bell mouth and an articulated connection to the exhaust system. The main difference between your laboratory chemical hood and the snorkel is that the latter does not fully surround the reaction at the point of release. For this reason, snorkels are not a substitute for a laboratory hood when handling toxic chemicals.
- Snorkels are far less effective in capturing dusts, mists, or fumes, and can typically only capture contaminants released within 6 inches (15 cm) of the unit. Snorkels are extremely susceptible to cross drafts.
- A good use for laboratory snorkels is the capture and removal of thermal updrafts from benchtop-heated processes, or as local ventilation for benchtop apparatuses such as gas chromatographs. Snorkels generally operate at 45 fpm.

Ductless Fumehoods

- Ductless fume hoods are designed to remove hazardous fumes and vapors from the work area by passing the exhaust air through a filter and/or adsorbent, such as activated charcoal.
- Because of the potential for unregulated use and personnel exposure through a “breakthrough” and desorption of vapors from the hood’s filtering system, EHS recommends using ducted hoods wherever possible. Ductless hoods should be used only when ducted hoods cannot be reasonably utilized or accommodated.



Additional Local Exhaust Devices



↑
Canopy Hood

Slot Table or Hood

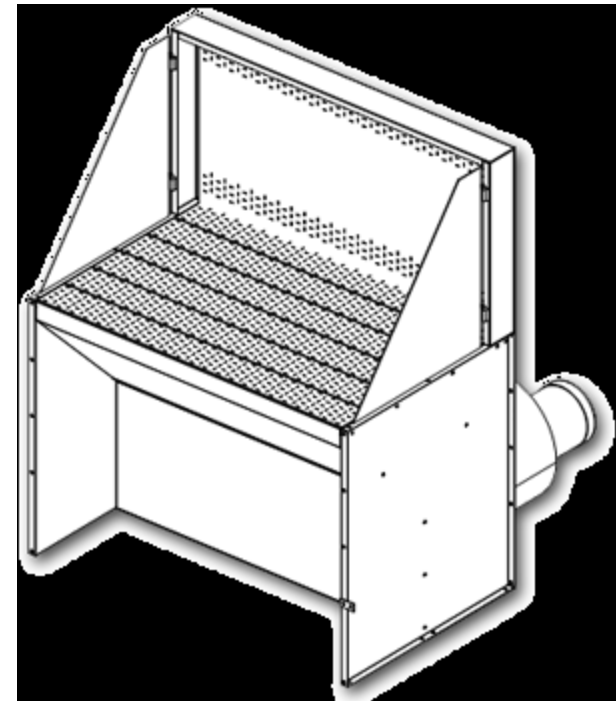
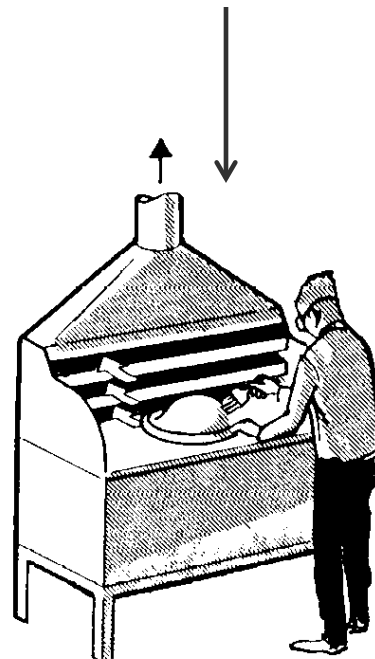

↑
Downdraft Table

Key Points

- Laboratory Chemical Hoods are integral safety devices that protect users and other lab and/or building occupants from exposures to toxic, offensive, or flammable materials.
- Check your hood and alarm prior to each use.
- Keep lab chemical hoods and adjacent work areas free of clutter. Keep paper and other solid objects away from the exhaust ducts and baffles because they can cause blockages and diminish hood performance.
- Keep the sash closed when the hood is not actively being used. This can help in case of a fire, spill, or explosion, as well as being potentially more economical.
- Always be familiar with the chemicals you are using in the hood and be aware of their dangers, whether they are toxic, oxidizing, flammable, or pyrophoric.
- Always wear your personal protective equipment when using a hood. The minimum standard is a lab coat, gloves, safety glasses, and closed toed shoes.
- Never put your head into a chemical fume hood.

Quiz Time

- To complete the Chemical Fume Hood Module, please [click here](#) for the quiz